

[Home](#) ■ [Обладнання](#) ■ [Обробка механічних забруднень](#)

HUBER Прес-мийка для шламу WAP® SL



Super Launder Wash Press

- volume, weight and disposal cost reduction of up to 85%
- compaction up to 50% DR
- high washed screenings quality of < 20mg BOD₅ / g DR
- Feeding through a launder channel or directly from a screen or conveyor

The WAP® SL operates in a batch mode. Screenings either drop into the launder tank directly from a screen or conveyor, or they are flushed into the tank through a launder channel. After a batch of screenings has been fed, the tank is filled up with wash water and agitated for an adjustable period by means of an impeller. The fecal matter is loosened and removed from the screenings by high turbulence and shear.

After the washing cycle has been finished, an automatic valve opens and the wash water drains through perforations in the trough. It returns, together with the fecal matter, to the wastewater flow. A screw in the trough conveys the screenings towards the mouth of a tube whereby they are, as an additional option, rinsed with spray water. The screw pushes the screenings through the pressure zone where they are compressed, dewatered and compacted before they are finally discharged through the discharge pipe into a dumpster or bagger.

[преимущества](#)

THE ADVANTAGES OF THE HUBER SCREENINGS WASH PRESS WAP® SL

- High-intensity washing in launder tank
- Washed screenings quality < 20 mg BOD₅ / g DR
- Compaction up to 50 % DS
- Volume, weight and disposal cost reduction by up to 85 %
- Screenings processing capacity of 2 - 12 m³/h (70 - 420 ft³/hr)
- Screen wastewater or process water can be used as wash water
- Sturdy design
- All structural parts, including the screw, are made of stainless steel to prevent electrochemical corrosion
- Fast payback due to great transportation and disposal cost savings

PDF скачать

 [проспект: HUBER Screenings Wash Press WAP/SL \(по-английски\)](#) [pdf, 239 KB]

примеры из практики

- [A Wastewater Screening and Screenings Processing Case Study at WWTP Hull \(Saltend\)](#)
- [Huber Technology upgrades the Inlet works at Duncrue Street, Belfast - a Wastewater case Study](#)
- [A successful combination: Launder Channel plus Wash Press SL](#)
- [Great HUBER Bar Screens and Wash-Presses in Dublin](#)
- [HUBER super-launder wash-press excels at Penrith WWTP](#)
- [Well Received Septic Sludge in Finland](#)

схема

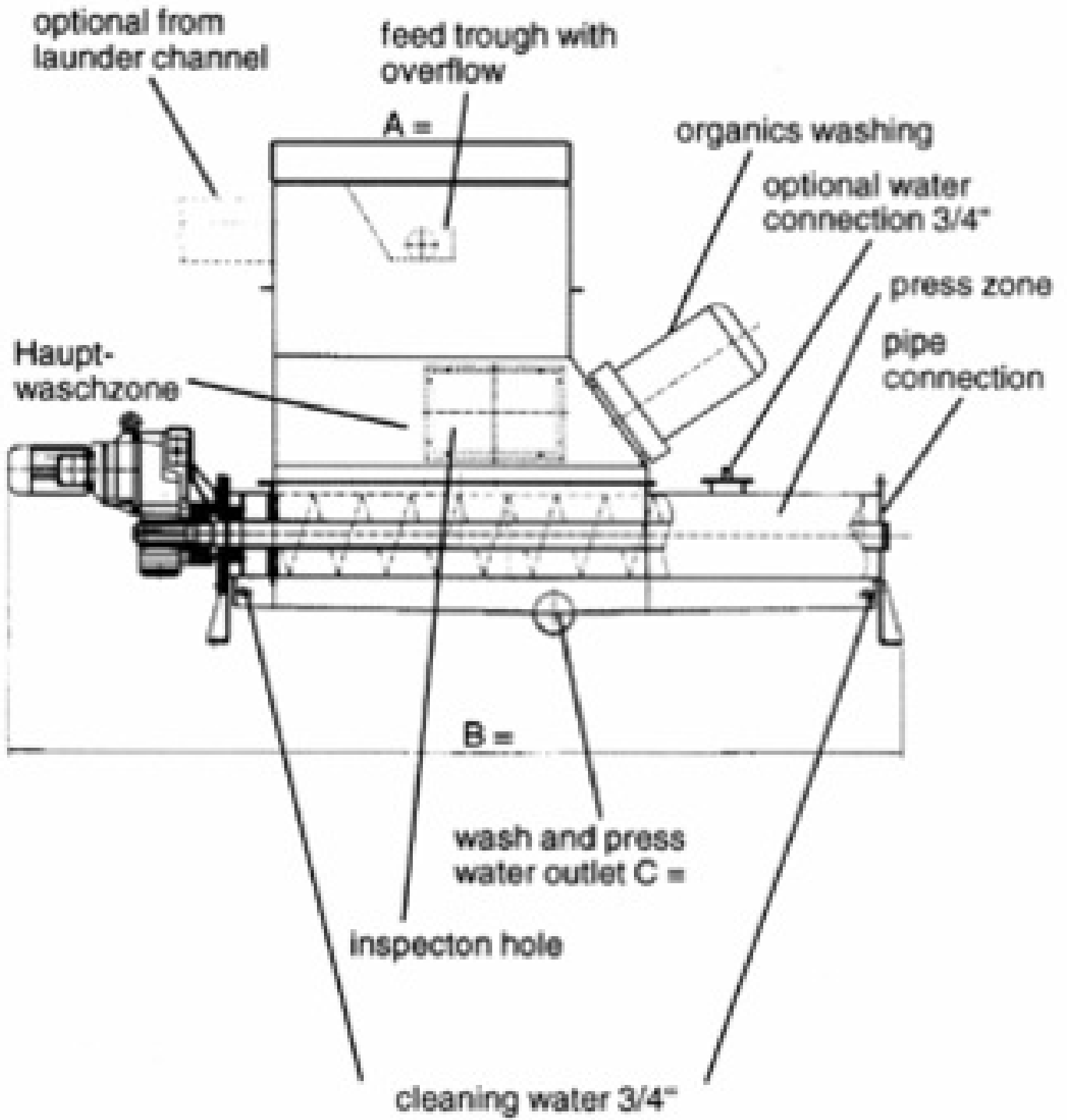

Media



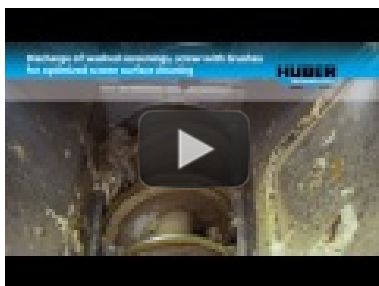

Video: Screenings Wash Press
WAP/SL at a municipal WWTP
[https://www.youtube.com/watch?
v=vylieOQUR_9o](https://www.youtube.com/watch?v=vylieOQUR_9o)

Інше обладнання серії Обробка механічних забруднень

- Прес-мийка для шламу WAP®
- Прес-мийка для шламу WAP® SL HP
- Прес-мийка для шламу WAP® L
- HUBER Гідроканал HLC
- HUBER Шнековий конвеєр
- HUBER Прес для механічного шламу Ro7
- Інтегрована система промивання шламу від органіки

Biuro Handlowe: ul. Ryżowa 51, 02-495 Warszawa, tel. + 48 22 572-28-60; fax + 48 22 572 28 68
Servis: ul. Ryżowa 51, 02-495 Warszawa, tel. + 48 22 572-28-60; fax + 48 22 572 28 98
KRS: 0000132940 Organ rejestrowy: Sąd Rej. dla m.st. W-wy w Warszawie, XIII Wydział Gospod. KRS

NIP 521-009-28-15
KRS 0000132940
Kapitał zakładowy 500.000 zł

Member of the HUBER group:
www.huber.de