

[Home](#) ■ [Produkty](#) ■ [Przeróbka osadu](#) ■ [Odwadnianie](#) ■ [HUBER Prasa ślimakowa S-PRESS](#)

HUBER Prasa ślimakowa S-PRESS



Sturdy, flexibly applicable sludge dewatering unit

The Screw Press consists in a cylindrical wedge wire basket. A preceding flocculation reactor ensures a sludge flock quality that allows dewatering of the sludge flocks and stabilises the flocculated sludge.

The free water drains through the basket whilst the solids inside the basket are conveyed gently upwards through the inclined basket by a slowly rotating screw. Continuous dewatering of the sludge takes place in the Screw Press with an increasing build-up of pressure due to the conical basket, which reduces the sludge cake volume in the press zone.

The filtration pressure inside the machine is adjustable by means of a pressure cone in the sludge discharge. Screen basket cleaning is performed by means of an automatic washing system.

Korzyści

ADVANTAGES OF THE HUBER SCREW PRESS S-PRESS

- Sludge volume reduction up to 90 %
- Minimum wear and vibration due to the low speed of the compacting screw < 5 rpm
- Insensitive to coarse material, designed for high solids loads
- Maximum system availability due to the virtually wear-resistant and clog-free stainless steel wedge section basket

- No need for lubrication
- Completely encapsulated, odour-free plant
- Low noise < 68 dB(A)
- No vibration
- Pneumatically controlled pressure cone system
- Extra sturdy design for industrial applications
- More than 500 installations worldwide

Do pobrania

[Brochure: HUBER Screw Press S-PRESS \(RoS3\)](#) [pdf, 218 KB]

Przykłady wdrożeń

- [New machine to dewater fermentation residues in dry fermentation](#)
- [ROTAMAT® Screw Press RoS 3 – an international success in paper industry applications](#)

Rysunek schematyczny

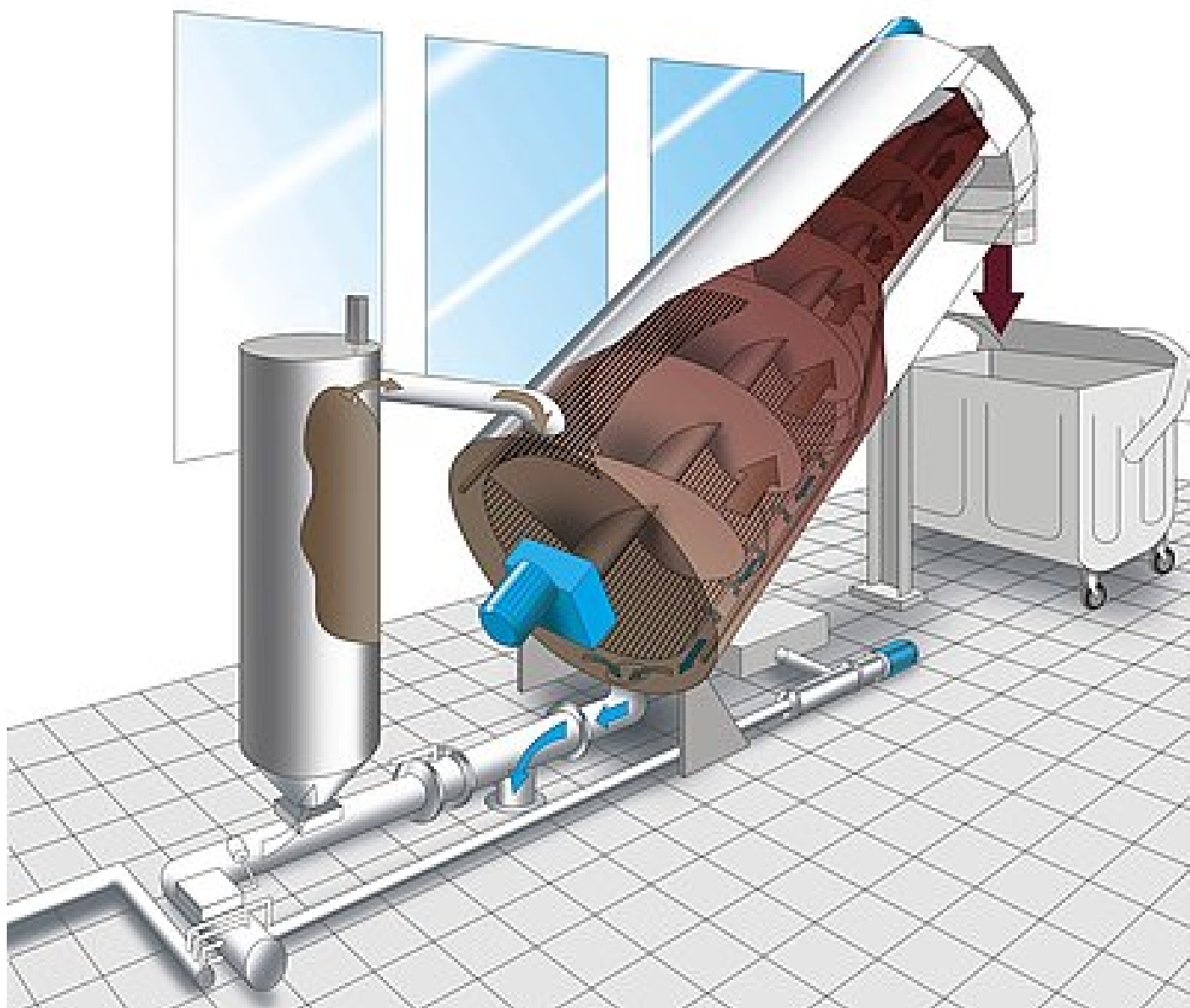

Zdjęcia



Inne produkty z tej grupy Odwadnianie

- [HUBER Prasa ślimakowa Q-PRESS®](#)
- [HUBER Prasa taśmowa B-PRESS](#)

Biuro Handlowe: ul. Ryżowa 51, 02-495 Warszawa, tel. + 48 22 572-28-60; fax + 48 22 572 28 68
Serwis: ul. Ryżowa 51, 02-495 Warszawa, tel. + 48 22 572-28-60; fax + 48 22 572 28 98
KRS: 0000132940 Organ rejestrowy: Sąd Rej. dla m.st. W-wy w Warszawie, XIII Wydział Gospod. KRS

NIP 521-009-28-15
KRS 0000132940
Kapitał zakładowy 500.000 zł

Member of the HUBER group:
www.huber.de